

REVISIONS			
LTR	DESCRIPTION	DATE	APPROVED

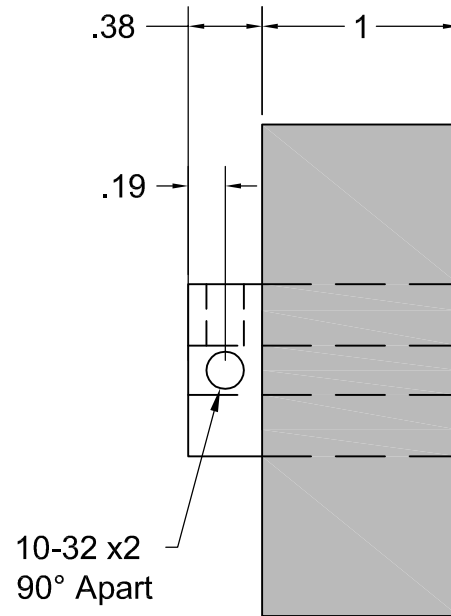

Durometer Options	
Replace XXX in Part Number with 3 letter durometer code from options below.	
40A = 40 SHORE A	80A = 80 SHORE A
55A = 55 SHORE A	90A = 90 SHORE A
70A = 70 SHORE A	

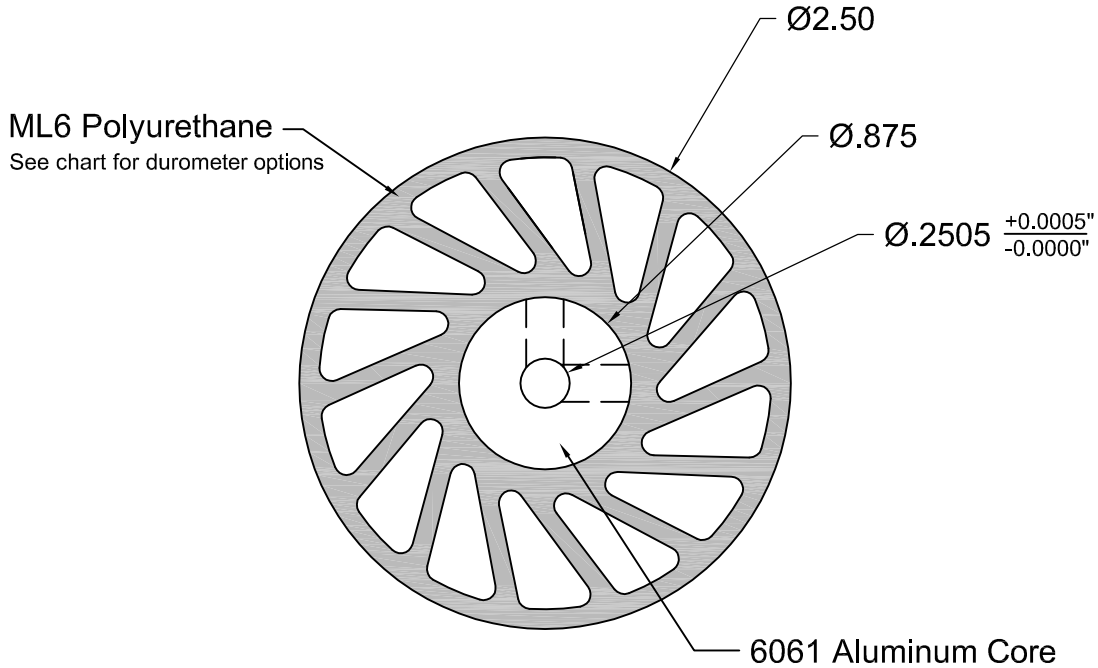

**MERIDIAN
LABORATORY**

2415 Pleasant View Rd. Middleton, WI 53562
(608) 836-7571 MeridianLab.com

UNLESS OTHERWISE SPECIFIED,
DIMENSIONS ARE IN INCHES AND
TOLERANCES ARE:

<u>FRACTIONS</u>	<u>DECIMALS</u>	<u>ANGLES</u>
±1/16	.X ± .1	±1/2°
	.XX ± .01	
	.XXX ± .005	

PROJECTION

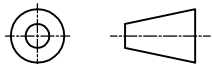

APPROVALS

DATE

DRAWN

AG

2/8/23

CHECKED

VRN

2/23/23

APPROVED

TITLE

2.5" x 1.0" ML6 NO-CRUSH WHEEL

PART NO.

NCW-300-XXX

MATERIAL

6061 AL & ML6 PU OVERMOLD

SCALE 1:1

REV. -

SHEET 1 of 1

ML6 CUST. BLOCK

This drawing is proprietary to Meridian Laboratory Inc. and may not be copied, disclosed, or distributed without explicit written permission. Design subject to change without notice.